

**12601**

Roll No. \_\_\_\_\_

Total No of Pages: **4****12601****B. Arch. I - Sem. (Main) Exam., Dec. - 2018****Architecture****1AR1 Mathematics****Time: 3 Hours****Maximum Marks: 80****Min. Passing Marks: 24***Instructions to Candidates:*

Attempt any **five questions**, selecting **one question** from **each unit**. All questions carry **equal** marks. Schematic diagrams must be shown wherever necessary. Any data you feel missing may suitably be assumed and stated clearly.

Units of quantities used/calculated must be stated clearly.

Use of following supporting material is permitted during examination.  
(Mentioned in form No. 205)

1. NIL2. NIL**UNIT- I**

Q.1 (a) In a shooting game the probability of A, B and C to hit the target are  $\frac{1}{2}$ ,  $\frac{2}{3}$  and  $\frac{3}{4}$  respectively. If all of them fire at a target, find the probability that atleast one of them hits the target. [8]

(b) Calculate the correlation coefficient for the following heights (in inches) of fathers (x) and their son (y) – [8]

x	65	66	67	67	68	69	70	72
y	67	68	65	68	72	72	69	71

**OR**

- Q.1 (a) In a book of 520 pages, 390 typographical errors occur. Assuming Poisson law for the number of errors per page, find the probability that a random sample of 5 pages will contain no error. [8]
- (b) Find the mean and variance for a normal variate X. [8]

**UNIT- II**

- Q.2 (a) Solve:  $(x^2 - 1) \frac{dy}{dx} + 2xy = 1$  [5]
- (b) Solve:  $2ydx + (2x \log x - xy)dy = 0$  [5]
- (c) Solve:  $\frac{d^3y}{dx^3} - y = (e^x + 1)^2$  [6]

**OR**

- Q.2 (a) Solve:  $\frac{d^2y}{dx^2} - 2 \frac{dy}{dx} + y = xe^x \sin x$  [5]
- (b) Solve:  $\frac{d^2y}{dx^2} + y = x^2 \sin 2x$  [5]
- (c) Solve:  $x \frac{dy}{dx} + y = y^2 \log x$  [6]

**UNIT- III**

- Q.3 (a) Investigate for consistency of the following equations and if possible find the solutions:  $4x - 2y + 6z = 8$ ;  $x + y - 3z = -1$ ;  $15x - 3y + 9z = 21$  [8]
- (b) Find the rank of the matrix [8]

$$\begin{bmatrix} 1 & 3 & 4 & 3 \\ 3 & 9 & 12 & 3 \\ 1 & 3 & 4 & 1 \end{bmatrix}$$

**OR**

Q.3 Find the eigen values and eigen vectors of the matrix –

[16]

$$A = \begin{bmatrix} 1 & 2 & 0 \\ 2 & 1 & -6 \\ 2 & -2 & 3 \end{bmatrix}$$

also find inverse of A, using Cayley-Hamilton theorem.

**UNIT- IV**

Q.4 (a) If  $u = e^{xyz}$  then prove that –

[4]

$$\frac{\partial^3 u}{\partial x \partial y \partial z} = (1 + 3xyz + x^2 y^2 z^2) e^{xyz}$$

(b) If  $u = \sin^{-1} \left( \frac{x^2 + y^2}{x + y} \right)$  then prove that-

[6]

$$x \frac{\partial u}{\partial x} + y \frac{\partial u}{\partial y} = \tan u$$

(c) If  $x^y + y^x = c$ , find  $\frac{dy}{dx}$

[6]

**OR**

Q.4 (a) Find the pedal equation of the parabola  $y^2 = 4a(x + a)$

[6]

(b) Find the angle of intersection of the following curves-

[6]

$$r = a(1 - \cos\theta), \quad r = (1 + \cos\theta)$$

(c) Show that in the equiangular spiral  $r = ae^{\theta \cot \alpha}$  the tangent is inclined at a constant

angle to the radius vector.

[4]

## UNIT- V

Q.5 (a) Evaluate  $\int_0^1 \int_{e^x}^e \frac{1}{\log y} dy dx$  by changing the order of integration. [8]

(b) Find the area included between the parabola  $y = 4x - x^2$  and the line  $y = x$  using double integration. [8]

**OR**

Q.5 (a) Evaluate  $\iiint_v x^2 dx dy dz$ , where  $v$  is the region bounded by the planes – [8]  
 $x = 0, y = 0, z = 0$  and  $x + y + z = a, a > 0$

(b) Evaluate  $\int_0^\infty \int_x^\infty \frac{e^y}{y} dx dy$  by changing the order of integration. [8]

---

12602

Roll No. \_\_\_\_\_

Total No of Pages: 2

12602

B. Arch. I - Sem. (Main) Exam., Dec. - 2018

Architecture

1AR2 Ecology & Built Environment

Time: 3 Hours

Maximum Marks: 80

Min. Passing Marks: 24

*Instructions to Candidates:*

*Attempt any five questions, selecting one question from each unit. All questions carry equal marks. Schematic diagrams must be shown wherever necessary. Any data you feel missing may suitably be assumed and stated clearly.*

*Units of quantities used/calculated must be stated clearly.*

*Use of following supporting material is permitted during examination.  
(Mentioned in form No. 205)*

1. NIL

2. NIL

### UNIT- I

Q.1 With the help of suitable examples, explain renewable and non - renewable resources. [16]

OR

Q.1 Discuss sustainable development. How is it important for society? [16]

### UNIT- II

Q.2 Discuss the types, causes, effects and monitoring of air pollution. [16]

OR

Q.2 Describe the factors responsible for climate change. How climate change influences quality of life? [16]

### **UNIT- III**

Q.3 Explain the concept and importance of environment friendly buildings. [16]

**OR**

Q.3 How can low waste or no waste technology help urban life? [16]

### **UNIT- IV**

Q.4 Write notes on –

(i) State Pollution Board [8]

(ii) Salient features of Wildlife (Protection) Act, 1972 [8]

**OR**

Q.4 Write notes on –

(i) National Environment Tribunal Act of India [8]

(ii) Biodiversity Board of India [8]

### **UNIT- V**

Q.5 What do you understand by practice of Environmental Impact Assessment, explain? [16]

**OR**

Q.5 Discuss the role of Environmental Impact Assessment in urban planning. [16]

---

12603

Roll No. \_\_\_\_\_

Total No of Pages: 4

12603

B. Arch. I - Sem. (Main) Exam., Dec. - 2018

Architecture

1AR3 Architectural Structures - I

Time: 3 Hours

Maximum Marks: 80

Min. Passing Marks: 24

*Instructions to Candidates:*

Attempt any **five questions**, selecting **one question from each unit**. All questions carry **equal marks**. Schematic diagrams must be shown wherever necessary. Any data you feel missing suitably be assumed and stated clearly.

Units of quantities used/calculated must be stated clearly.

Use of following supporting material is permitted during examination.  
(Mentioned in form No. 205)

1. NIL2. NIL**UNIT- I**

Q.1 A String is subjected to the forces 4 bkN and 'P' kN. Determine the magnitudes of 'P' and the tensions in the various portion of the string. [16]

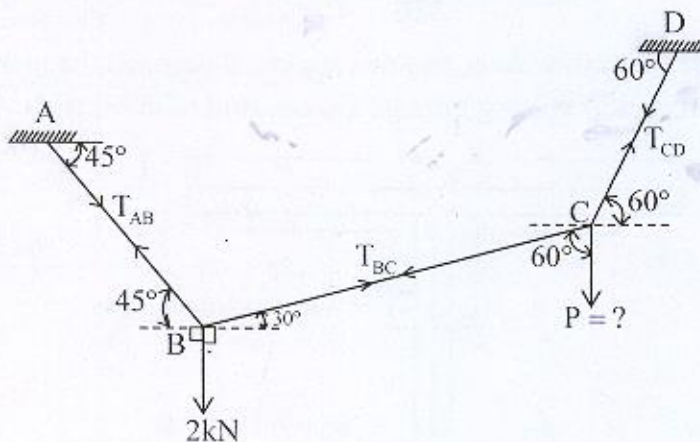

**OR**

Q.1 Determine the magnitude and direction of the resultant of the following four force acting at a point – [12+4=16]

- (i) 20 kN Pull  $30^\circ$  from North towards East.
- (ii) 25 kN Push  $45^\circ$  from South towards West.
- (iii) 15 kN Push  $60^\circ$  from North towards West.
- (iv) 20 kN Push  $60^\circ$  from South towards East.

**UNIT- II**

Q.2 Find the Centroids and Moment of Inertia of the following section about Centroidal Axes. [6+10=16]

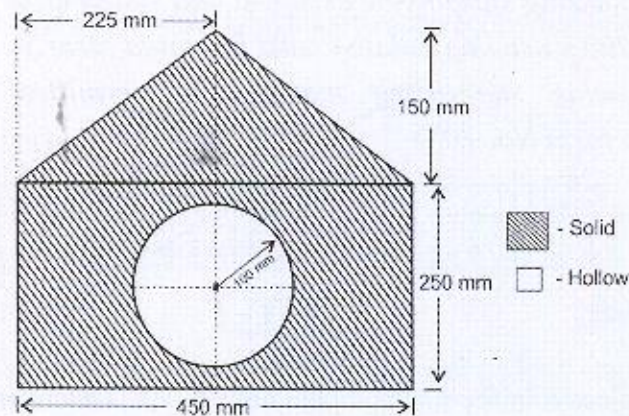

**OR**

Q.2 A T – Beam is made up of two plates and two angles. Determine the moment of Inertia of T – Section about an axis passing through the centroid of the section. [16]

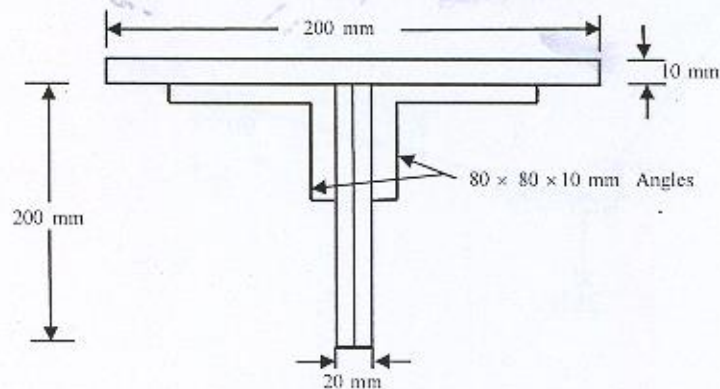



### UNIT- III

Q.3 In a lifting Machine, the effort required to lift loads of 50 kN and 40 kN were 15 kN and 10 kN respectively. If the velocity ratio of the lifting machine is 20, determine the following: [4+4+4+4=16]

- (i) Law of the machine
- (ii) Efficiency corresponding to loads of 50 kN & 40 kN
- (iii) Effort lost in friction in both cases
- (iv) The Maximum efficiency which can be expected from the machine

OR

Q.3 What do you mean by First system of pulleys? Derive the Mechanical Advantages & Velocity ratio of the first system of pulleys. [4+12=16]

### UNIT- IV

Q.4 An Axial pull of 50 kN is acting on a bar consisting of three lengths. If the Young's Modulus of bar material =  $2.1 \times 10^5 \text{ N/mm}^2$ , Determine – [8+8=16]

- (i) Stresses in each section
- (ii) Total extension of the bar

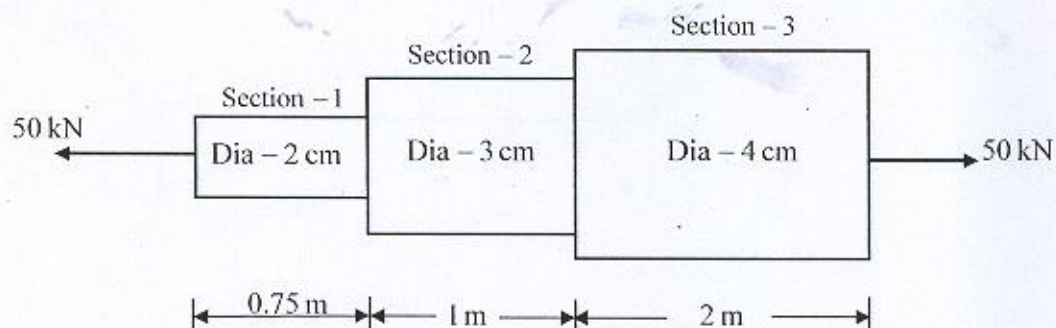

**OR**

Q.4 A bar of 3cm dia. is subjected to a pull of 90 kN. The measured extension on gauge length of 300 mm is 0.3 mm and change in dia. is 0.003 mm.

Calculate the -

[4+4+4+4=16]

- (1) Young's Modulus of bar [E]
- (2) Poisson's Ratio [ $\mu$ ]
- (3) Bulk Modulus [K]
- (4) Shear Modulus [G]

**UNIT- V**

Q.5 Determine the reactions of a beam which carries the following loads -

[16]

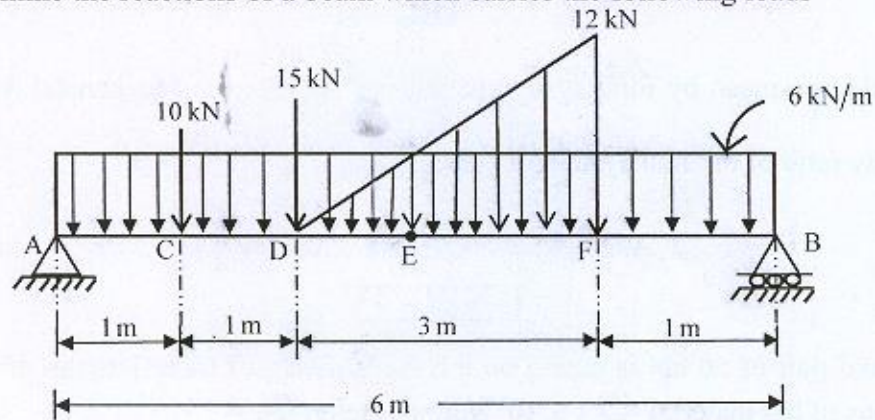

**OR**

Q.5 What are the various loads that are considered in the design of a tall building? Briefly explain them, and also state that which Indian standard codes are followed for these loads.

[4+7+5=16]